

**More Applications.
More Versatility.**

SP-H open solution

**All from a
single source.**



SP-H series overview

We are enlarging the raceway diameters on our pinion driven heavy slew drive series SP-H, namely the 1055, 1155, 1255, 1355 and the 1455. Due to their size, we will be manufacturing them without any housing.

All the components will be perfectly matched together.



Maximum torque M_d max of the individual sizes

CAUTION: The duty per minute is limited. Please always observe the explanations in the technical information section of the IMO slew drive catalogue ST311 (from page 60).

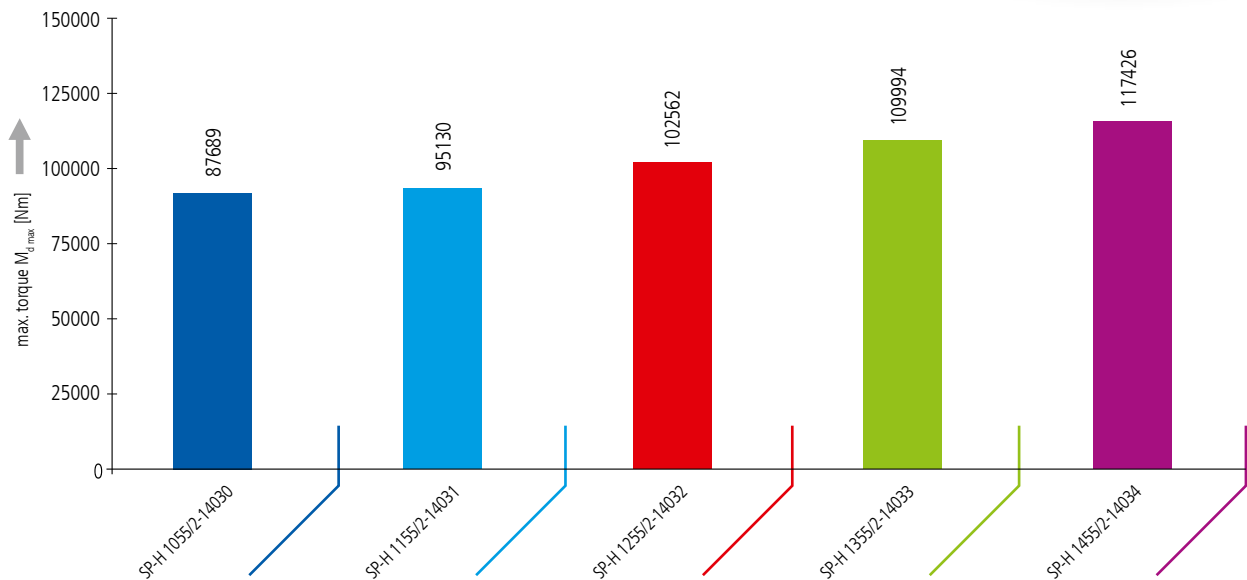

Limiting load diagrams of the individual sizes for compressive loads

Please always observe the explanations in the technical information section of the IMO slew drive catalogue ST311 (from page 60).

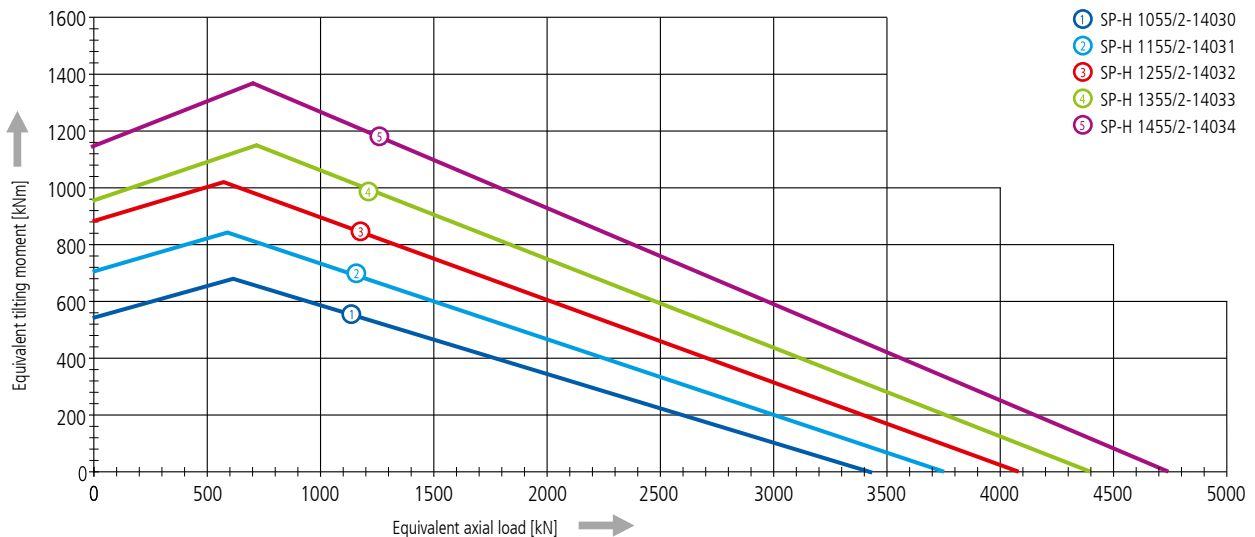

Size SP-H 1055

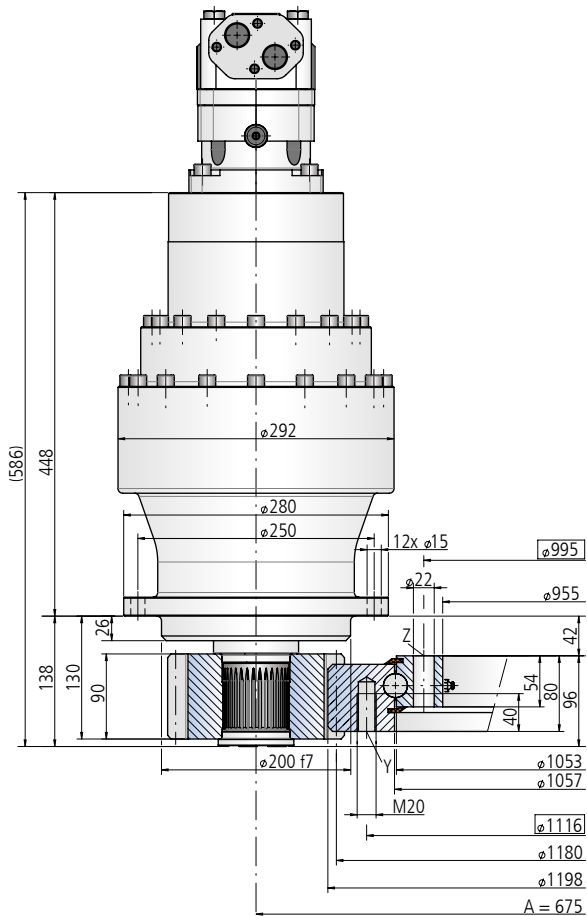

Mounting holes

Y = 30 drill holes M20- 40 deep, evenly distributed
Z = 30 drill holes Ø22, evenly distributed

Lubrication ports

4 conical grease nipples on internal diameter
Raceway system supplied pre-lubricated
Gear teeth must be lubricated in the application

The mounting structure must support the inner ring to at least Ø1055

Drawing number SP-H 1055/2-14030

Module	m	[mm]	10
Number of teeth, wheel	z₂	[-]	118
Number of teeth, pinion	z₁	[-]	16
Slew drive gear ratio	i	[-]	7.38
Overall gear ratio incl. gear box	i_{ges}	[-]	209.45
Max. torque	M_{d max}	[Nm]	87698
Nom. torque $S_5 = 1 \text{ bei } n = 2 \text{ min}^{-1}$	M_{d nom}	[Nm]	58174
Max. holding torque*	M_{h max}	[Nm]	87698
Static load rating, radial	C_{o rad}	[Nm]	1280
Static load rating, axial	C_{o ax}	[kN]	3426
Dynamic load rating, radial	C_{rad}	[kN]	382
Dynamic load rating, axial	C_{ax}	[kN]	447
Weight, incl. 20 kg for hydraulic motor MT 160		[kg]	294

* Optionally with brake

The hydraulic/electric motor is selected according to the actual requirements and customer specification.

Selection example:

Performance data with hydraulic motor MT 160

Pressure differential	Δp	[bar]	198
Oil flow	Q	[l/min]	73
Output speed	n	[min ⁻¹]	2
Max. achievable torque	M_d	[Nm]	87698

Limiting load diagram for compressive loads

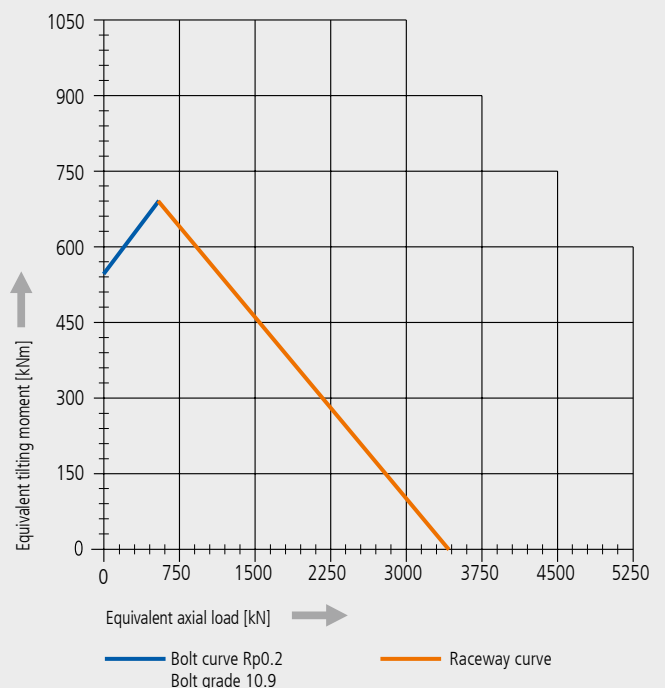

Please always observe the technical information!

Size SP-H 1155

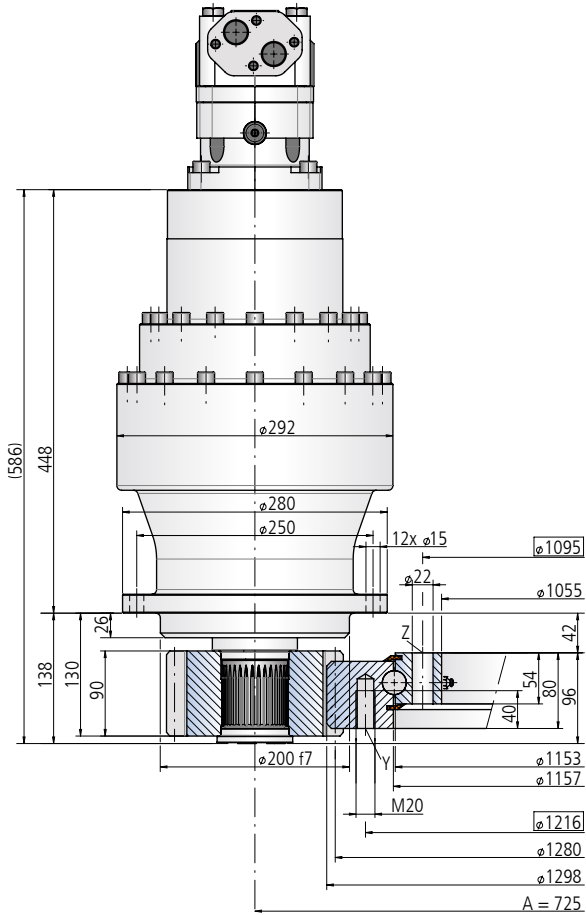

Mounting holes

Y = 36 drill holes M20- 40 deep, evenly distributed
 Z = 36 drill holes Ø22, evenly distributed

Lubrication ports

4 conical grease nipples on internal diameter
 Raceway system supplied pre-lubricated
 Gear teeth must be lubricated in the application

The mounting structure must support the inner ring to at least Ø1155

Drawing number SP-H 1155/2-14031			
Module	m	[mm]	10
Number of teeth, wheel	z₂	[-]	128
Number of teeth, pinion	z₁	[-]	16
Slew drive gear ratio	i	[-]	8.00
Overall gear ratio incl. gear box	i_{ges}	[-]	227.20
Max. torque	M_{d max}	[Nm]	95130
Nom. torque $S_5 = 1 \text{ bei } n = 2 \text{ min}^{-1}$	M_{d nom}	[Nm]	63232
Max. holding torque*	M_{h max}	[Nm]	95130
Static load rating, radial	C_{o rad}	[Nm]	1401
Static load rating, axial	C_{o ax}	[kN]	3751
Dynamic load rating, radial	C_{rad}	[kN]	395
Dynamic load rating, axial	C_{ax}	[kN]	461
Weight, incl. 20 kg for hydraulic motor MT 160		[kg]	309

* Optionally with brake

The hydraulic/electric motor is selected according to the actual requirements and customer specification.

Selection example:

Performance data with hydraulic motor MT 160

Pressure differential	Δp	[bar]	198
Oil flow	Q	[l/min]	79
Output speed	n	[min ⁻¹]	2
Max. achievable torque	M_d	[Nm]	95130

Limiting load diagram for compressive loads

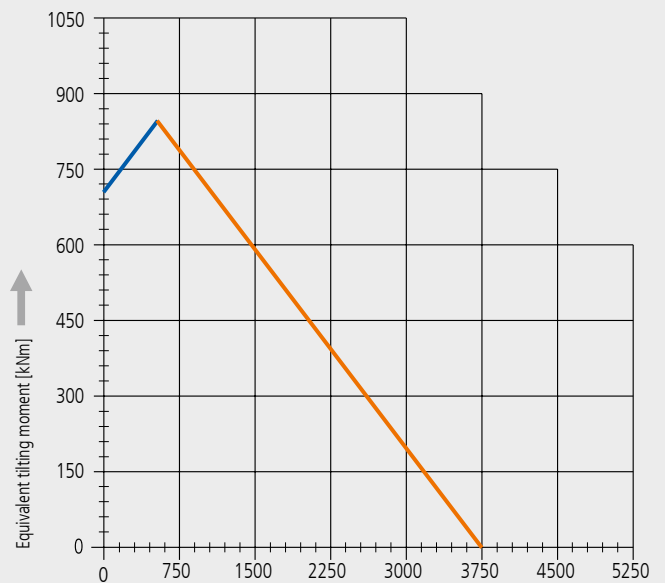

Equivalent axial load [kN]

— Bolt curve Rp0.2
 Bolt grade 10.9

— Raceway curve

Please always observe the technical information!

Size SP-H 1255

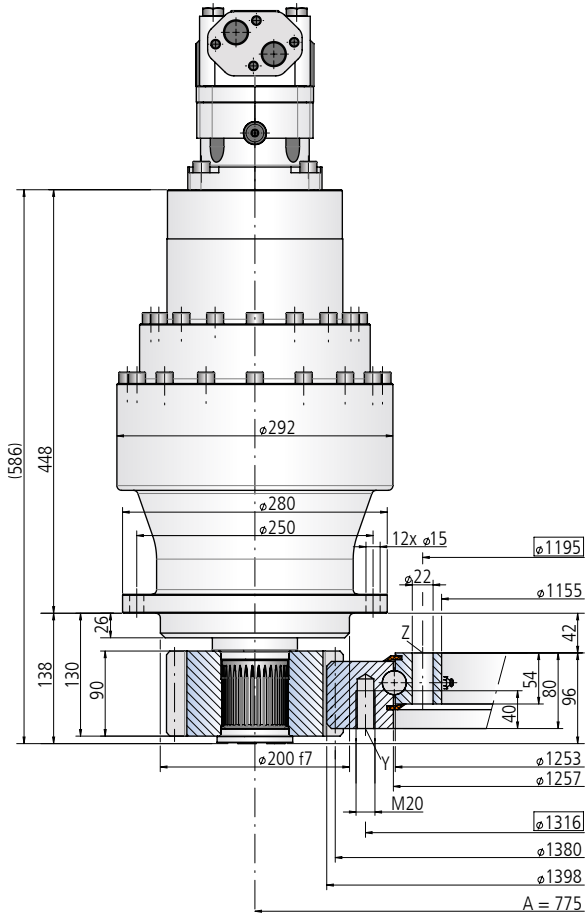

Mounting holes

Y = 42 drill holes M20- 40 deep, evenly distributed
 Z = 42 drill holes Ø22, evenly distributed

Lubrication ports

4 conical grease nipples on internal diameter
 Raceway system supplied pre-lubricated
 Gear teeth must be lubricated in the application

The mounting structure must support the inner ring to at least Ø1255

Drawing number SP-H 1255/2-14032			
Module	m	[mm]	10
Number of teeth, wheel	z₂	[-]	138
Number of teeth, pinion	z₁	[-]	16
Slew drive gear ratio	i	[-]	8.63
Overall gear ratio incl. gear box	i_{ges}	[-]	244.95
Max. torque	M_{d max}	[Nm]	102562
Nom. torque $S_5 = 1 \text{ bei } n = 2 \text{ min}^{-1}$	M_{d nom}	[Nm]	68379
Max. holding torque*	M_{h max}	[Nm]	102562
Static load rating, radial	C_{o rad}	[Nm]	1523
Static load rating, axial	C_{o ax}	[kN]	4076
Dynamic load rating, radial	C_{rad}	[kN]	408
Dynamic load rating, axial	C_{ax}	[kN]	478
Weight, incl. 20 kg for hydraulic motor MT 160		[kg]	324

* Optionally with brake

The hydraulic/electric motor is selected according to the actual requirements and customer specification.

Selection example:

Performance data with hydraulic motor MT 160

Pressure differential	Δp	[bar]	198
Oil flow	Q	[l/min]	85
Output speed	n	[min ⁻¹]	2
Max. achievable torque	M_d	[Nm]	102562

Limiting load diagram for compressive loads

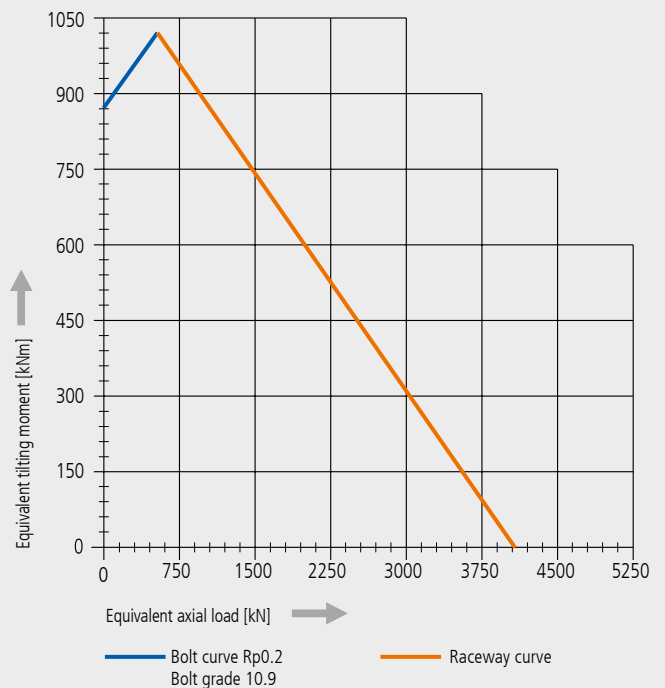

Please always observe the technical information!

Size SP-H 1355

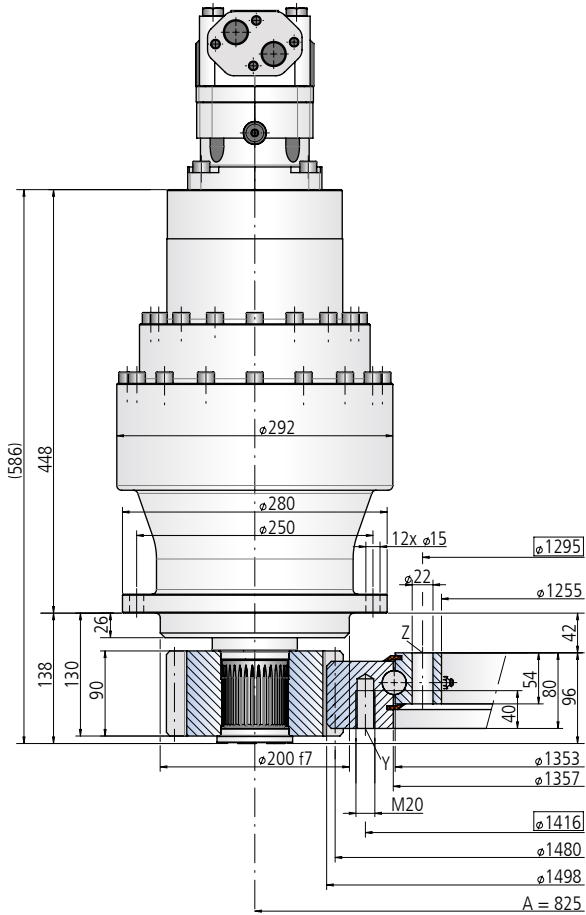

Mounting holes

Y = 42 drill holes M20- 40 deep, evenly distributed
 Z = 42 drill holes Ø22, evenly distributed

Lubrication ports

4 conical grease nipples on internal diameter
 Raceway system supplied pre-lubricated
 Gear teeth must be lubricated in the application

The mounting structure must support the inner ring to at least Ø1355

Drawing number SP-H 1355/2-14033			
Module	m	[mm]	10
Number of teeth, wheel	z₂	[-]	148
Number of teeth, pinion	z₁	[-]	16
Slew drive gear ratio	i	[-]	9.25
Overall gear ratio incl. gear box	i_{ges}	[-]	262.70
Max. torque	M_{d max}	[Nm]	109994
Nom. torque $S_5 = 1$ bei $n = 2 \text{ min}^{-1}$	M_{d nom}	[Nm]	73482
Max. holding torque*	M_{h max}	[Nm]	109994
Static load rating, radial	C_{o rad}	[Nm]	1644
Static load rating, axial	C_{o ax}	[kN]	4401
Dynamic load rating, radial	C_{rad}	[kN]	420
Dynamic load rating, axial	C_{ax}	[kN]	491
Weight, incl. 20 kg for hydraulic motor MT 160		[kg]	341

* Optionally with brake

The hydraulic/electric motor is selected according to the actual requirements and customer specification.

Selection example:

Performance data with hydraulic motor MT 160

Pressure differential	Δp	[bar]	200
Oil flow	Q	[l/min]	90
Output speed	n	[min ⁻¹]	2
Max. achievable torque	M_d	[Nm]	109994

Limiting load diagram for compressive loads

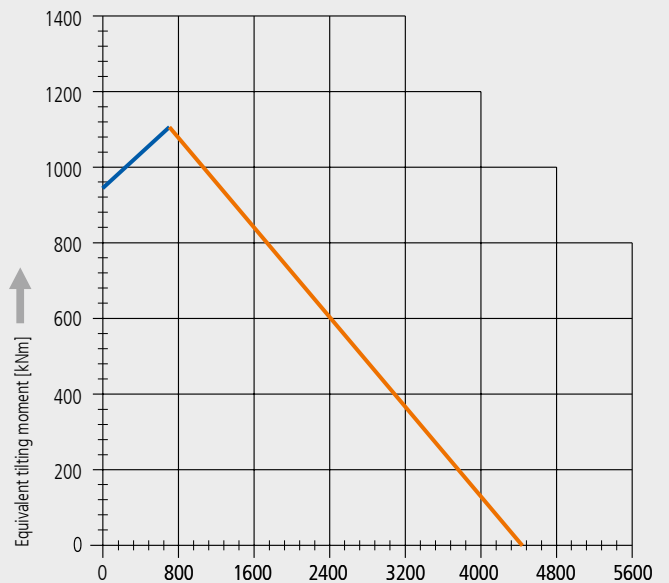

Equivalent axial load [kN]

— Bolt curve Rp0.2
 Bolt grade 10.9

— Raceway curve

Please always observe the technical information!

Size SP-H 1455

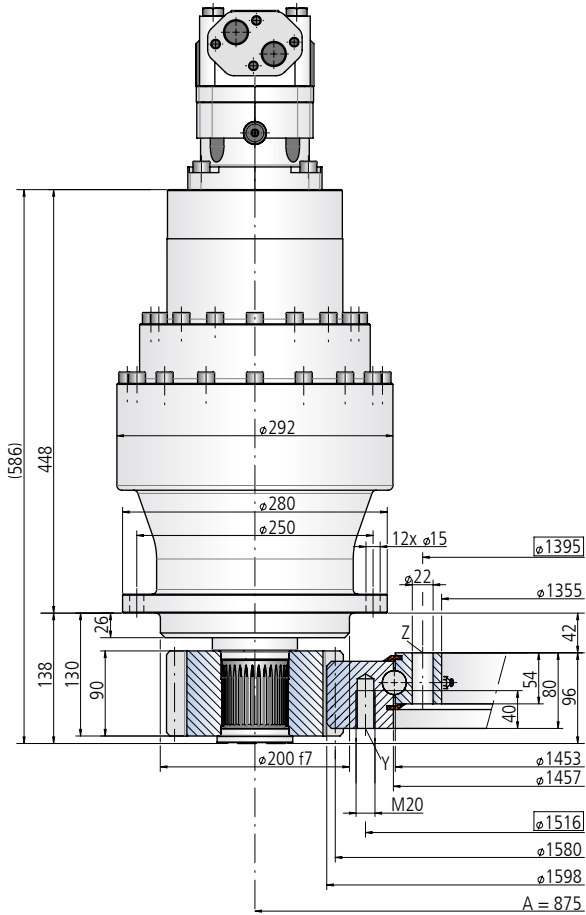

Mounting holes

Y = 48 drill holes M20- 40 deep, evenly distributed
 Z = 48 drill holes $\phi 22$, evenly distributed

Lubrication ports

4 conical grease nipples on internal diameter
 Raceway system supplied pre-lubricated
 Gear teeth must be lubricated in the application

The mounting structure must support the inner ring to at least $\phi 1455$

Drawing number SP-H 1455/2-14034			
Module	m	[mm]	10
Number of teeth, wheel	z₂	[-]	158
Number of teeth, pinion	z₁	[-]	16
Slew drive gear ratio	i	[-]	9.88
Overall gear ratio incl. gear box	i_{ges}	[-]	280.45
Max. torque	M_{d max}	[Nm]	117426
Nom. torque $S_5 = 1$ bei $n = 2 \text{ min}^{-1}$	M_{d nom}	[Nm]	78566
Max. holding torque*	M_{h max}	[Nm]	117426
Static load rating, radial	C_{o rad}	[Nm]	1765
Static load rating, axial	C_{o ax}	[kN]	4725
Dynamic load rating, radial	C_{rad}	[kN]	430
Dynamic load rating, axial	C_{ax}	[kN]	503
Weight, incl. 20 kg for hydraulic motor MT 160		[kg]	356

* Optionally with brake

The hydraulic/electric motor is selected according to the actual requirements and customer specification.

Selection example:

Performance data with hydraulic motor MT 160

Pressure differential	Δp	[bar]	200
Oil flow	Q	[l/min]	97
Output speed	n	[min ⁻¹]	2
Max. achievable torque	M_d	[Nm]	117426

Limiting load diagram for compressive loads

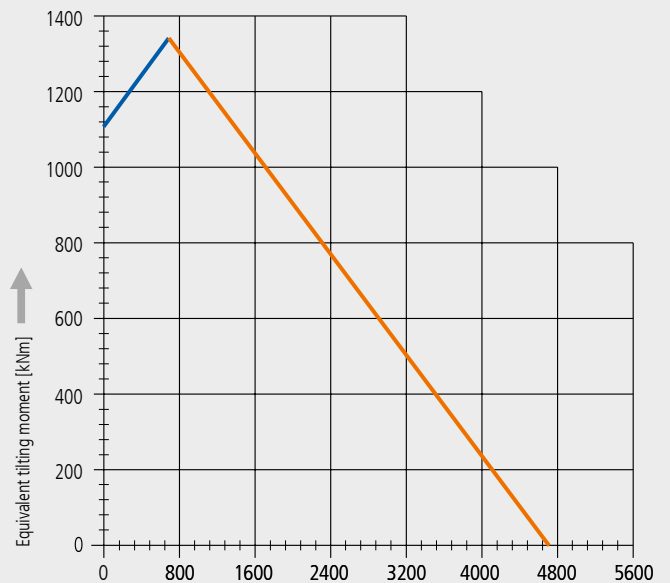

— Bolt curve Rp0.2
 Bolt grade 10.9

— Raceway curve

Please always observe the technical information!

Variety of Applications:

Examples of pinion driven IMO slew drives series SP-H open solution

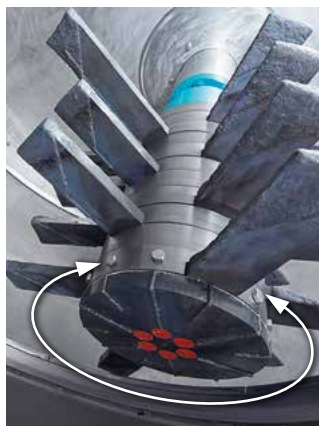
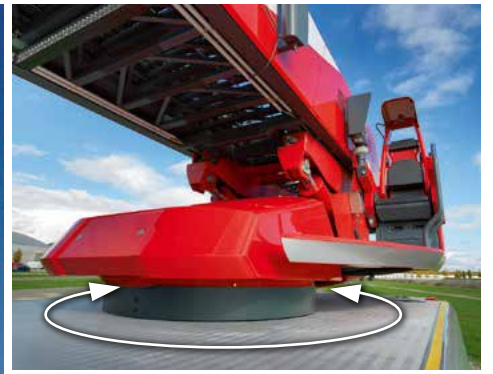

IMO

IMO GmbH & Co. KG

Imostrasse 1
91350 Gremsdorf
Deutschland

Telefon: +49 9193 6395-0
Telefax: +49 9193 6395-1140
sales@imo.de

www.imo.de